

# The Masthead



News from Westlawn Institute of Marine Technology

Volume 1, Issue 1

April, 2007

## Inside This Issue

Westlawn Reaccredited	Pg. 1
NABD Hall of Fame	Pg. 2
Design Tips	Pg. 2&3
Ventilation Fundamentals	Pg. 3 thru Pg. 9
In Memoriam	Pg. 10

## Welcome

Dear Students and Friends,

Welcome to the first issue of *The Masthead*, Westlawn's free news letter providing information about what is happening at Westlawn, developments in boating and the boating industry, as well as technical notes. We hope that you will find the articles interesting and informative as well as useful in the workplace or in your studies. We look forward to your comments and will publish them in later issues as space permits.

Thanks for joining us, and welcome aboard.

*Norm*

Norman Nudelman, Editor

[nnudelman@abycinc.org](mailto:nnudelman@abycinc.org)

Westlawn is the not-for-profit educational affiliate of:



## ABYC Your Source for Boatbuilding Standards and Reference Material

An invaluable resource for marine books and reference is [The American Boat & Yacht Council \(ABYC\) Ship's Store](#). Here you will find [books](#), [ABYC Compliance Guidelines](#), downloadable [ABYC Standards](#), downloadable [ISO Documents](#), and [Study Guides](#) for ABYC certification courses. ABYC literally writes the standards for safe boats. Members get substantial discounts on books and ABYC courses. If you're not a member, [sign up now!](#)

If you are not already a subscriber, [Click Here to Sign up for our Free Email Newsletter](#) and receive your very own copy next time

## Westlawn Reaccredited



Accreditation is a voluntary process that involves an intensive evaluation of the institution which must prove that it meets established standards. On April 23, 1971 Westlawn was first accredited by the Accrediting Commission of [Distance Education and Training Council \(DETC\)](#). Institutions accredited by DETC are examined every 5 years to insure that they are meeting the established academic and business standards. Westlawn was re-accredited in 1976, 1981, 1985, 1991, 1996, 2001, and 2006. A letter from the Accrediting Commission in January 2007 confirmed that we were re-accredited with the high marks for the full five year period without reservations. Accredited schools must also submit reports annually as an additional check to indicate that standards are continually being met.

DETC executive director Michael P. Lambert stated that, "Westlawn's implementation of a systematic approach to distance learning is effective and impressive. The curriculum offered by Westlawn can only be described as outstanding; it truly meets the needs of the small-craft design industry."

The DETC Accrediting Commission is listed by the [U.S. Department of Education](#) as a "nationally recognized accrediting agency." Like the six regional accrediting agencies, DETC's Accrediting Commission is reviewed periodically by the U.S. Department of Education to insure that it meets the criteria for federal recognition as published in Title 34 of the Code of Federal Regulations. DETC's Accrediting Commission is also recognized by the [Council for Higher Education Accreditation \(CHEA\)](#). CHEA is a non-governmental agency that reviews and recognizes accrediting agencies that accredit degree granting institutions.



### Design Tip :

#### Why do I need to draw with a pencil ???

This is a question we sometimes see from Module 1 Yacht Design students who would like to jump into computer-aided design before they have learned the fundamentals of marine drawing and drafting. Student Paulo Alves Souza posted an excellent response to such a question on the [Westlawn Forum\\*](#). He said:

*The Westlawn approach of, know how to do by hand before you go to software, is sure to help students get the feeling of lines, shapes, volumes, balance, harmony. Take my word for it, I have used AutoCAD since its Release 12 (1990/1) and to this day all my sketches, and preliminaries are hand drawn. It is easier and more productive. And when you come up with something you like, you can always scan it!."*

Drawing with pencil helps to develop the creative areas in the right side of the brain helping the student to gain better eye/hand coordination and an improved sense of form and proportion.

\*The Westlawn Forum is the online meeting place where students go to discuss course material with other students and instructors or just get to know each other.

## L. Francis Herreshoff Inducted Into the NABD Hall of Fame

L. Francis Herreshoff, one of the most influential yacht designers of the 20th century, was inducted into the North American Boat Designers Hall of Fame at the annual meeting of the American Boat & Yacht Council on February 14, at the Bass Museum in Miami Beach FL.

"Of all the designers in history, L. Francis had the most influence on me personally," said Dave Gerr, director of Westlawn, "His books, *'The Common Sense of Boat Design'* and *'Sensible Cruising Designs,'* sat on my drawing table for almost daily reference. He drew the only U.S. 30-square-meter boat, *Oriole*. It was stored next to my boat for a few years, and sighting down her lean, graceful hull would take one's breath away."

Herreshoff's work included small craft ranging from canoes to large cruising yachts. Notable are the 1930 America's Cup J-boat, *Whirlwind*, the R-class sloop *Yankee*, the cruising ketches *Bounty*, and *Tioga*. Launched in 1936, the magnificent *Tioga* finished first in twenty-four of her initial thirty-seven races.

Established in 2004, the NABD Hall of Fame has inducted six designers. In addition to this years inductee, past recipients include John Alden, Nathaniel Greene Herreshoff, C. Raymond Hunt, Philip L. Rhodes, and Olin Stephens.

The North American Boat Designers Hall of Fame recognizes outstanding achievement by individuals in the field of boat and yacht design. The Hall of Fame is soon to be housed at [Mystic Seaport](#) in Mystic Connecticut. At the permanent exhibit, engraved crystal plates will be on display to honor each inductee together with photos, drawings and historical reference material.



### Design Tip :

#### Cavitation & Propeller Blade Area

When propeller blade loading is too high (too much thrust is forced onto too small a propeller), cavitation will occur. Westlawn Director, Dave Gerr, derived this formula for calculating maximum blade area (total area for all blades) needed to avoid cavitation.

## Alumni Gallery



*Hetairos*, a 38.25m (125ft) Ketch, designed by Westlawn Graduate Bruce King, & built by Abeking & Rasmussen, in Germany. Thousands of yachts have been designed by Westlawn alumni. To see a selection of these by Bruce King and many other Westlawn Alumni, go to the Design Gallery at [www.westlawn.edu](http://www.westlawn.edu)



L. Francis Herreshoff at lathe  
© Mystic Seaport Collection,  
Mystic, CT, #99-8-221  
Courtesy of Paul Glynn

$$\text{Area in square inches} = \frac{(100 \times \text{shaft hp})}{(\text{knots} \times \sqrt{\text{knots}})}$$

$$\text{Area in Square Centimeters} = \frac{865 \times \text{Shaft hp}}{(\text{knots} \times \sqrt{\text{Knots}})}$$

### Mark Your Calendar

The second annual [Westlawn Student and Alumni Mystic Meet](#) is scheduled for Saturday and Sunday July 28 and 29. Plan to arrive Friday July 27 because we'll start early on Saturday morning. The meet will take place at the same time as Mystic Seaport's Antique and Classic Boat Rendezvous. There will be plenty to see and do!

We have arranged for very inexpensive hotel rooms just a few minutes away.

More details to come but **hold the date**.

[CLICK HERE](#) to read about last year's Mystic Meet, including photos.



Westlawn is affiliated with [Mystic Seaport](#). Visit the Seaport to learn about the history of boats, boatbuilding, and design.



### Design Tip: Updates to Multihull Text (Book 122)

A new appendix with additional notes on multihull design is ready for downloading.\* Module 2 Yacht Design students should download the PDF file located on the Westlawn Forum online at: [All Forums, Module2, Lesson YD 21 – Multihulls, UPDATE Multihulls](#). Follow the instructions for printing and inserting the new material into your Module 2 textbook.

\*Course material is only available to Westlawn students.

### Passenger-Compartment Ventilation Fundamentals

By Dave Gerr, © 2007 Dave Gerr

If you live in the Northeast, then you know that Florida's not exactly a bad place to spend some time in February. As you can imagine then, I wasn't at all disappointed to find I'd have to work the Miami boat show aboard a boat my office designed. When I got there the weather, in fact, exceeded expectations, and—except for a couple of days that actually reached 84° F (29° C)—conditions were flawless. One afternoon in particular stands out in my mind. It was about 72° F (22° C) and 35-percent humidity. A steady 15-knot breeze blew in from the northeast, and the blue sky was dotted with puffy clouds just dense enough to throw occasional welcome shadows in the brilliant sun. Aboard our boat we had all the windows open and—with the light wind whistling through—it was even a bit chilly in the shade (just a bit).



**The Classic Cowl Vent On A Dorade Box**

Courtesy Marinco/Nicro Ventilation Systems

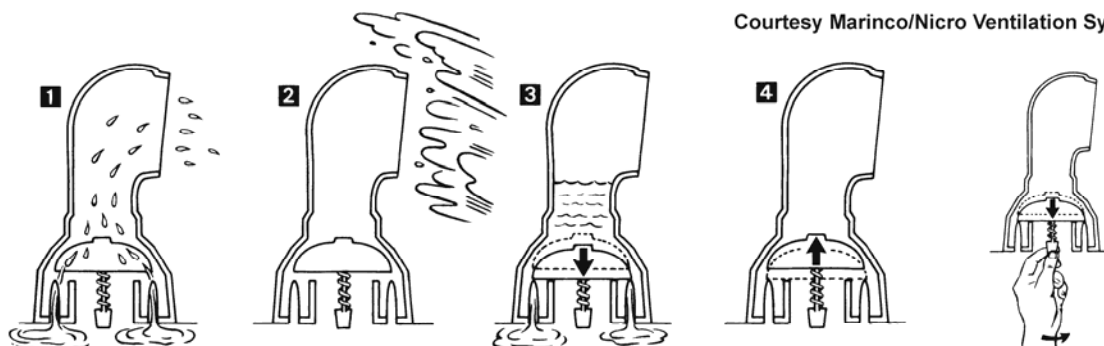

1 Rain and spray is directed away from deck opening where it drains out weep holes at bottom of trap.

2 In extreme conditions, a green water intrusion gives our new water trap a chance to shine.

3 The weight of the green water pushes down on the damper, shutting off the trap 100%. The green water drains off onto the deck through the four weep holes at the bottom of the water trap.

4 When the green water is gone, the damper pops up again and ventilation continues.

The damper can be shut-off from below by pulling down on damper arm and rotating it 1/4 turn. This will shut off the water trap 100%.

### Nicro Cowl Vent On Watertrip With Damper

Of course, one of the perks of having to do a boat show is getting to check out what other builders are doing. When a couple of my crew returned aboard, I decided to steal a few hours and poke around some of the other vessels. A client of mine had mentioned that he'd liked a few features on a 60-foot, production, high-speed motorcruiser. So, I Set off for a look at it.

**Air From Where?**

Though this was a fairly conventional boat of this type, it did certainly have some well-thought-out details. I clambered into the engine compartment, which was clean and open, and then out and up onto the flybridge, where visibility was good. Going below, I thought the builder had done a fine job on the joinerwork, though—as all too common on production boats—there were darn few access panels for maintenance and repair. Ambling toward the bow, I found myself in the forward guest stateroom. It was light, with large hanging lockers, and seemed a bit cool. “Incredible weather,” I thought to myself, and then it hit me. It wasn't the weather it was the boat's air/conditioning. In fact—even though this was a perfect clear almost cool day outside—the A/C was running full bore.

A glance around and the reason was clear. The forward stateroom (and all the staterooms below deck) had no opening windows. In fact, the forward stateroom windows couldn't have been made to open safely, because—with the great flare at the bow—these windows (even though high up on the topsides) actually faced down at the water, at nearly a 40 degree angle. If there'd been opening ports installed and you forgot to close them underway, well, you'd soon have given the accommodations a nice saltwater bath. As a result—with no other means of ventilation—the air/conditioner had to run and had to run all the time, even on a beautiful comfortable day like this one. “Imagine,” I thought to myself, “what this boat just smell like after you had it closed up for a few weeks in the summer sun, and came aboard for a cruise. Why the combined smell of styrene and mildew would probably knock you flat.” There wasn't even a hatch in the overhead, which could have been opened. (This, by the way, is bad for another reason, as there ought to be two avenues of escape from every compartment, and a hatch works as the other avenue.)

**A Comfort Component**

Ventilation is a key component in comfort aboard any boat, yet I doubt you spent much time considering it the last time you were planing a new design, doing a retrofit, or conducting a survey. In fact, almost all boats will benefit from added ventilation. Really good ventilation, doesn't just make life more comfortable aboard. It also, reduces rust, mildew, and decay. And it lessens the likelihood of seasickness. It also means that you have to run the A/C less frequently, which is quieter and saves the owner money and our small planet some pollution.

Courtesy Marinco/Nicro Ventilation Systems

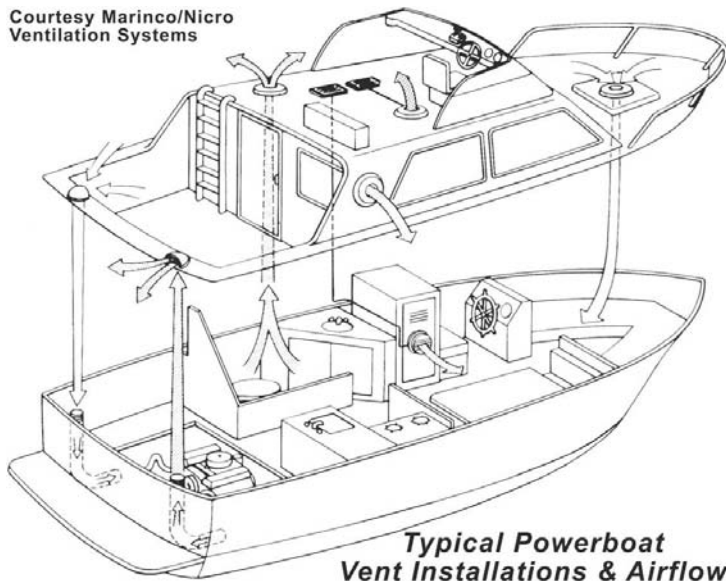

**Typical Powerboat Vent Installations & Airflow**

Courtesy Marinco/Nicro Ventilation Systems

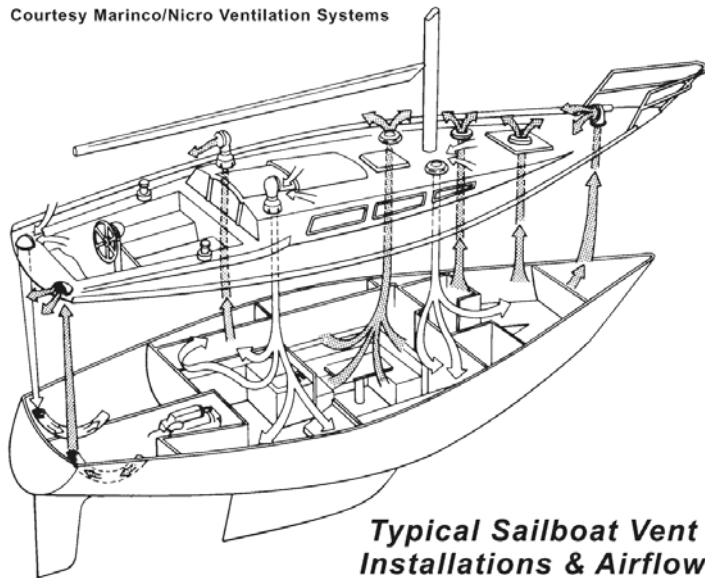

**Typical Sailboat Vent Installations & Airflow**

**Ventilation—providing adequate airflow—has four primary jobs aboard any boat:**

- 1) Provide for the safety and comfort of the crew
- 2) Avoid mildew, mold, rust, and decay
- 3) Ensure efficient operation of internal-combustion engines and other machinery
- 4) Dissipate any dangerous or undesirable gases or fumes

**VENTILATION OF PASSENGER COMPARTMENTS**

**Ventilation Measure**

Ventilation is a subject which can occupy an HVAC (heating, ventilation, and air-conditioning) engineer for

a lifetime of study. Reducing system noise, maximizing efficiency, laying out intricate duct systems, and more all are complex subjects in themselves. A full discussion of ventilation includes heat and humidity control. For instance, when it gets cold you want less airflow through a compartment, but you can't seal the compartment airtight, you need to breath. Humidity and air velocity combine to govern comfort, and—in cargo ships—can make the difference between a load arriving fresh or completely spoiled. For our basic discussion, however, we'll assume we're simply dealing with keeping things cool and comfortable in relatively simple systems, and that the crew will actively go around closing ventilators, hatches, and windows, and turning off fans as the weather gets colder. What we're going to do here is review simple approaches to meeting basic ventilation requirements on boats.

**The Volume Change Rate (VCR)**

The amount of ventilation can be evaluated as the number of air changes in a given volume (in a compartment) in a given time—usually in one hour—say, 5 changes of air per hour for a bilge area, for example. This is the volume change rate (VCR).

**Volume Change Rate (VCR) Of Different Compartments**

Compartment	VCR per Hour	Time to Change Air
Galley	10 to 20 times	3 to 6 minutes
Lavatories & W.C.s	8 to 10 times	5 to 7 minutes
Sleeping Cabins	6 to 8 times	7 to 10 minutes
Saloons	5 to 10 times	7 to 12 minutes
Forepeak & Lazarette	5 times	12 minutes
Bilges	5 times	12 minutes
Storage Compartments	8 to 12 times	5 to 7 minutes
Engine Compartments	150 to 250 times	0.24 to 0.4 minutes

**Airflow in Cubic Feet Per Minute (CFM)**

As a practical matter, you need to find the airflow in cubic feet per minute (CFM) required to meet the VCR requirement for a given compartment. Say you had a master stateroom that was 9.9 ft. long x 8.8 ft. wide. It has a head compartment in one corner that is 3.25 ft. x 4.67 ft. wide. Headroom is 6.5 feet. Then:

9.9 ft. x 8.8 ft. x 6.5 ft. headroom = 566 cu.ft.

3.25 ft. x 4.67 ft. x 6.5 ft. headroom = 98 cu.ft.

566 cu.ft. - 98 cu.ft. = 468 cu.ft.

VCR should be between 6 to 8 times per hour.

6 x 468 cu.ft. = 2,808 cu.ft./hr., or 2,808 cu.ft./hr ÷ 60 min./hr. = 46.8 CFM

to

8 x 468 cu.ft. = 3,744 cu.ft./hr., or 3,744 cu.ft./hr ÷ 60 min./hr. = 62.4 CFM

(Note: It's customary in passenger spaces to use gross compartment volume, as we have here. For machinery spaces, net compartment volume is employed.)

We'd need to install blowers or passive ventilators that provided this flow rate to meet our VCR requirement.

For passenger spaces, you should also check the minimum amount of ventilation based on the amount of air required to keep each person comfortable in fairly warm weather. This can be worked out as follows:

**How Much Air Per Person?**

For reasonable comfort, each crewmember needs about 15 cubic feet of air per minute (CFM). Obviously, when it's blowing hard a small passive vent will deliver more air than when there's barely a breeze. What we need, however, is ventilation when it's hot and there is little wind. Accordingly, the boat should be fitted with vents that'll deliver 15 CFM per person in light winds—say 4 knots. The following table gives the cross-sectional vent areas that will provide the required flow in just 4 knots of wind. It assumes a roughly standard cowl vent sitting on a water trap, or a good quality mushroom vent.

Standard cowl and mushroom vents come in sizes ranging from 3 to 10 inches and have the following minimum opening cross-section.

Vent Requirements Per Person		
No. Of Crew	CFM	Area, sq.in.
1	15	21
2	30	37
3	45	51
4	60	64
5	75	77
6	90	92
7	105	110
8	120	131
9	135	157
10	150	190
11	165	229
12	180	278
13	195	335
14	210	404
15	225	484
16	240	578
17	255	686
18	270	809
19	285	949
20	300	1107

If this boat routinely carried six crew, you'd read off the table that the required 90 CFM, which would be provided by 92 square inches of vent area, in a summertime 4-knot wind. The second table shows that this would call for seven or eight 4-inch vents. Few boats have this number, so it's no wonder that so many are uncomfortable below when it's hot out. In fact—although 3-inch vents are quite common—they're really too small to give enough ventilation. Three-inch vents should only be used for passenger-compartment ventilation on the tiniest craft, where you may have no option but to go this small. If you have hatches or windows that can be left open or partially open in most conditions, you can deduct the area they contribute from the vent requirements; however, keep in mind when you do close everything down all you'll have left to breath with is the vents alone.

Round Vent Areas	
Vent Areas Dia., in.	Area, sq.in.
3	7.1
4	12.6
5	19.6
6	28.3
7	38.5
8	50.2
9	63.6
10	78.5

**Checking Air Per Person Against the VCR**

We should check the vent-per-person requirement against individual compartment's VCR as well as the entire boat. For instance, we found we needed between 46.8 and 62.4 CFM to meet the VCR requirements for the master stateroom above. This stateroom will sleep two people, so based on 15 CFM per person that's just 30 CFM. You should select the larger of the two where possible, so we'd go with vents delivering at 46.8 CFM in four knots of wind. Which—from the table—would be four 4-inch vents (40.5 sq.in.).

**Rod Stephens's Vent Rule**

If 92 square inches of vent area seems like a lot, Sparkman & Stephens founding designer Rod Stephens rule of thumb for vent area for a single-deck vessel is:

Total vent area, sq.in. = WL, ft. x Beam Overall, ft.

If our *Ocean Breeze* were a 38 footer with a 32 foot waterline and 11 ft. - 10 in. beam overall it'd require 32 ft. WL x 11.83 ft. Beam Overall = 378 sq.in. vent area!

This rule assumes that a reasonable portion of the vent area, will come from partly open hatches with dodgers over them in most conditions. If you took 25 percent of this (allowing the remaining 75 percent to come from hatches) you'd end up with 94 sq.in., which is about the same as the dedicated vent area calculated above.

Note that a more complete statement of Rod Stephens's vent rule is that 1 sq.in. of vent area is required for every square foot of cabin area (not volume) in temperate climates, and 1.5 sq.in. for every square foot of cabin area in tropical climates. This can be restated as:

Vent area, temperate climates = cabin area ÷ 144

Vent area, tropical climates = cabin area ÷ 96

Our example master stateroom was 9.9 ft. long x 8.8 ft. wide. It has a head compartment in one corner that is 3.25 ft. x 4.67 ft.

Net stateroom square footage is:

9.9 ft. long x 8.8 ft. wide	=	87.1 sq.ft.
<u>- 3.25 ft. long x 4.67 ft. wide</u>	=	<u>- 15.2 sq.ft.</u>
Total	=	72 sq.ft.

For temperate climates:

72 sq.ft. ÷ 144 = 0.5 sq.ft.  
 0.5 sq.ft. x 144 in./sq.ft. = 72 sq.in.

This would be six 4-inch ventilators, which is not likely to be practical. You could approach this requirement by using, say, four 5-inch ventilators (78.4 sq.in.) or three or four 4-inch ventilators combined with hatches, with dodgers, or ventilated companionway doors, and such, that are arranged so they can be left open in bad weather.

**Windows, Hatches, Skylights**

The fact is that—properly designed—windows, skylights, and hatches can and should contribute to vent area in warm weather. Including these items, you can approach or even exceed Rod Stephens’s rule. The photo below shows a motor-cruiser my office designed. This is the same model as the one at the boat show. Note that almost every single window you see opens. There is a huge skylight in the wheelhouse roof and there are large sliding doors. Even when its’ raining and unpleasant out, at least a quarter of these windows, or hatches can be left partly open, without water coming in. (Which ones to open depend on wind and spray direction, obviously.) In most conditions, the total vent area in use—even in bad weather—is greater than Rod Stephens rule. In fact, the first two of these boats did not have air/conditioning at all. The boat pictured is based out of Florida. At the same time, with the hot-water heating system and the windows and hatches buttoned up, this boat is also warm and snug in 30° F (-1° C) weather. Of course, buttoned up like this, the numerous mushroom vents still provide adjustable fresh air, which is vital.

The photo showing the inside of *Summer Kyle* (next page), gives the inside view of another of these vessels and the amount of both light and air designed in.

**Solar-Power Air**

One of the best solutions to getting air below is the solar-powered mushroom vent. Standard 4-inchers deliver about 18 CFM. What’s more, they do it every day the sun shines whether you’re aboard or not, and they don’t even drain the batteries. Better still are the day/night solar vents equipped with built in ni-cad batteries. These gizmos store up enough juice on sunny days to keep them going overnight. Indeed, once fully charged, they can run nearly 48 hours without sun. High-output solar vents are also available. Nicro Fico’s 4-incher pulls about 26 CFM. Although not inexpensive, a few of these nearly add up to a cool mountain breeze. Two or three of these solar-powered vents installed over the galley and the head will keep your *Ocean Breeze* mildew free and smelling fresh as a daisy. Even better—since these vents aren’t tied into your electric system—you leave them running all the time, even when you’re not aboard—without fear of draining the batteries. As a result, your boat will be fresh and well ventilated even after you open it up for a cruise after a long absence.

For solar-powered vents located where the vent won’t get direct sun (such as on the cabin side), there are remote solar panels available to power each vent.

**Electric-Power Air—Blowers and Ducts**

Larger yachts may have compartments on a lower deck or inboard, where it isn’t convenient or possible to install a vent directly through the cabin roof. In a 180 footer with twin lower decks, this gets into full HVAC design with integrated heating and air-conditioning. On vessels under 90 feet, or so, you can generally provide natural ventilation through relatively short ducts and keep the air/conditioning and heating separate. In fact, this may be the best approach, because—even if the heating and air-conditioning system go offline—the separate, simple ventilation system will still provide basic comfort.

Again, you can determine the air required by the either the VCR for a given compartment or by the number of people expected to be in that compartment. But you have to allow for the losses in the ducting system that directs the air to the compartment. Detailed analysis of a ventilation duct is complex, but a simple approximation can be use for small, simple ducted systems up to about 12 feet long as follows:



**ABYC Estimated Effect of Blower-System Components**

Item	Percent Loss of Blower Rated Capacity
Ducting	2% per ft. of length
Ducting Bends - 90°	10% each bend
Clamshell Vent Intake	20%
Louver	20%
Screen - 1/4-in mesh	10%

Using the example master stateroom above we found we needed between 46.8 and 62.4 CFM, say 55 CFM. This stateroom is entirely below the aft saloon. The windows on the hull side are too close to the waterline to open safely. Vent ducts can run down from the cabin roof. They enter from a mushroom vent on the roof, and straight down the cabin side for 9 feet to exit out louver grilles via a 90-degree bend. Percent loss of blower capacity is:

9 feet x 2% per foot = 18%  
 90 degree bend = 10%

Louver grille = 20%  
 Total approximate loss = 58%  
 Effective vent output = 100% - 58% = 42% of blower's rated CFM output

Required blower capacity is then:  
 55 CFM ÷ 0.42 = 131 CFM

This would be handled nicely by a standard 3-inch squirrel-cage blower, rated at 150 CFM.

**Blower Configurations or Types**

As a general rule, the most efficient and most common types of blowers are squirrel-cage blowers (centrifugal blowers). Axial blowers (helicoidal blowers) look like (are really) what we think of as "fans." Though in smaller sizes and less-expensive units axial blowers aren't usually as effective, in larger sizes they can work quite well.

It can be difficult to locate blowers of any type larger than 4-inches diameter. Two sources for large marine blowers are Delta-T Systems of Jupiter, Florida ([www.deltatsystems.com](http://www.deltatsystems.com)) and Gianneschi & Ramacciotti blowers, available in the U.S. through Cole Marine Distributing, Ft. Lauderdale, Florida ([www.colemarine.com](http://www.colemarine.com)). The drawing shows an axial blower from Delta-T Systems, which is available from 12- to 36-inches diameter, with capacities ranging from 800 to over 25,000 CFM. Moving this much air takes a great deal of power, and large blowers—moving over around 1,200 CFM—need to be powered off the AC electric system. Up to about 1,200 CFM, you can find blowers that will run off 24-volt DC.

**Controlling Noise**

Air flowing too fast through the duct or louvers causes unacceptable noise. To keep this under control, the cross-section area has to be large enough to keep velocity to under 600 feet per minute (fpm). Over this air velocity and you'll need to line or jacket the air-ducts with sound insulation. In fact, some home and industrial systems use just this approach—small-diameter, high-velocity air ducts with heavy sound insulation. This reduces the amount of space such duct systems take up, but few such systems are available for marine use. In any case, we can find the velocity in fpm for the below-deck cabin above as:



**Squirrel-Cage Blower**

A 3-inch duct has an section area of 7.1 sq.in.  
 7.1 sq.in. ÷ 144 sq.in./sq.ft. = 0.049 sq.ft.  
 131 CFM ÷ 0.049 sq.ft. = 2,673 fpm – too fast; need a larger duct  
 Required duct section for 600 fpm:  
 131 CFM x 144 sq.in./sq.ft. ÷ 600 fpm max = 31.44 sq.in.

$$\text{Dia.} = 2 \times \sqrt{31.44 \text{ sq.in.} \div \pi} = 6.3 \text{ in.} \quad \text{- use 6-in. dia. duct to keep noise down}$$

The on-off-switch would ideally be located next to the main overhead cabin light by the stateroom door, and clearly labeled as "Ventilator."

**Providing an Intake Path**

For most of the cabin ventilation we've been considering, we're assuming that some of the vents are working as intake and some are working as exhaust as shown in the

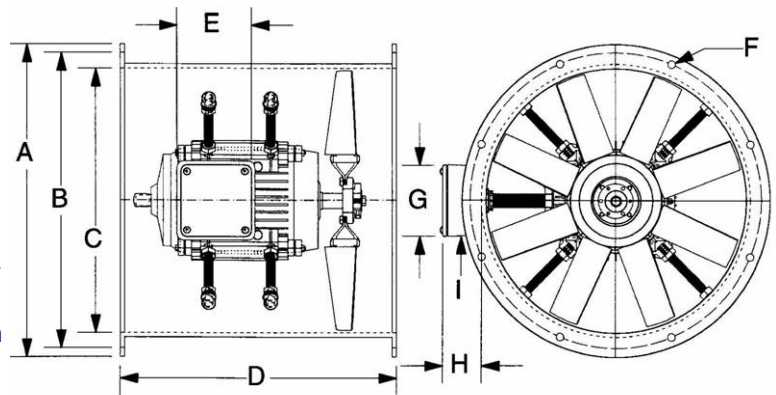

Photo: Starke Jette

**Ventilation Inside "Summer Kyle"**



Nicro schematics. In addition, there is free exchange of air between cabins within the boat and to the outside. This is the *permeability* ( $\mu$ ) of the structure. Permeability is generally enough so that cabins can *share* intake and exhaust air between them. In fact, it this permeability to the outside is usually great enough that provisions for additional “make-up air” (in air/conditioning systems) is unnecessary in most boats under 120 feet, or so. (Make-up air, is air taken into the air/conditioning system through a dedicated outside vent to ensure that sufficient fresh air gets into the accommodations.)



***Axial Blower From Delta-T Systems***

For a cabin below decks requiring a 9-foot duct run, intake air due to permeability or from another cabin, from a vent located somewhere else on deck, can't be counted on. For this reason, a second passive intake duct should be provided, the same diameter, or one size larger than the blower duct. This is assuming that the blower is on the exhaust duct.

#### **Intake Air Travels a Straight Path; Outlet Air Does Not**

It's important to keep in mind that intake air generally travels a straight path out of the outlet opening in a compartment until it hits something. Outtake air (suction) tends to be sucked into its inlet from the entire general area nearby. I once made the mistake of installing an engine-air intake and outlet high up on the same aft bulkhead in the engine compartment, one port and the other starboard. The vents were large but the engine room got terribly hot. A quick check during sea trials with a cigarette showed that the inlet air was blowing straight across the bulkhead from port to starboard and exiting immediately. Luckily, this was easily corrected by installing an air-duct hose over the outlet opening and running it down to the lower starboard corner of the engineroom. This immediately corrected the problem and created a nice diagonal, circular rotation of airflow in and around the entire machinery space.

Apply this principle to any vent system you install. For our below-deck master stateroom, the intake air louver grille should be, say, low down and forward on the starboard side, with the outlet (exhaust) air grille should be high up and aft on the port side. This will also suck out the warm air high up, as warm air rises.

#### **Exhaust or Intake?**

An important thing to keep in mind is that all powered vents for areas with unpleasant smells should be exhaust vents. This sucks the bad air out and draws sweet air in. It's tempting to try and blow fresh air into a head or galley, but don't do it—you'll simply blast the foul air into the rest of the boat. You can blow into sleeping accommodations, salons, or other social gathering areas, however.

#### **Mushroom Vents On Hatches**

Often—if a boat has plenty of hatches—one of the easiest places to install a mushroom vent (solar powered or passive) is in the middle of a hatch. The advantage is that you don't have to cut any of the deck structure or worry about hidden wiring or plumbing when installing the vent. When the hatches are closed the vents work well. The drawback is that you effectively loose the vents when the hatches are open. I've installed lots of vents in hatches, but—where possible—I prefer to install them on the deck (or cabin side) proper, so *both* the open hatches and the vents work with the hatches open.

#### **Staying Alive**

Another absolutely vital consideration is carbon monoxide. I can't stress this strongly enough—be very, very careful not to locate vents where they can suck in exhaust gases from the engine, genset, cabin heater, or stove. Carbon monoxide and carbon dioxide are silent killers. Every season I read of a family that went to sleep aboard some evening and never woke up because of CO poisoning. This is serious business. You should get a copy of ABYC's standard TH-22 “Educational Information About Carbon Monoxide” and review it carefully.

### In Memoriam

Tom Fexas, one of the most talented and innovative motoryacht designers of the 20<sup>th</sup> century, died Wednesday November 29, 2006, in Stuart, Fla. He was 65 years old.

Mr. Fexas was born in the Borough of Queens, New York City. He attended the State of New York (SUNY) Maritime College where earned a bachelor's degree in marine engineering. He later graduated from the Westlawn Institute of Marine Technology where he studied Yacht Design. He completed the Westlawn yacht design program in his off-duty hours while serving as third engineer on the SS

Independence. From 1965 through 1977 he worked for the Electric Boat division of General Dynamics as a nuclear project engineer for Trident Class submarines.

He established the firm of Tom Fexas Yacht Design in 1966 and since then, more than 1,000 of his designs have been built by some of the world's most prestigious boat builders in the U.S. and abroad. Inspired by the commuter boats and rumrunners of the early 20<sup>th</sup> century, Tom designed the sleek and shapely Midnight Lace which created a sensation when introduced at the 1978 Fort Lauderdale

Boat Show. He was a sought-after writer and had a monthly column in Power & Motoryacht magazine. He also served as a member of the Westlawn Institute's board of directors.

He is survived by his wife, Regina Fexas; his mother, Antonia Fexas; and his sister, Penelope Casas.

The Fexas tradition of meticulously executed innovative design is being continued by the firm's talented yacht designers and engineers



Tom Fexas



### The Masthead

News from Westlawn Institute of Marine Technology

Westlawn Institute of Marine Technology  
c/o Mystic Seaport, PO Box 6000  
Mystic, CT 06355

Phone: 860 572 7900

Fax: 860 572 7039

E-mail

Student Services: [pschulte@abycinc.org](mailto:pschulte@abycinc.org)

The Masthead: [nnudelman@abycinc.org](mailto:nnudelman@abycinc.org)



We're on the Web at  
[www.westlawn.edu](http://www.westlawn.edu)

### Who Are We

Westlawn is the not-for Profit Educational Affiliate of the [American Boat and Yacht Council](#) (ABYC). Our School is Nationally Accredited by the [Distance Education and Training Council](#) (DETC), and approved by the [Connecticut Department of Higher Education](#).

### Our Mission

Founded in 1930, the mission of the Westlawn Institute of Marine Technology is threefold:

- To provide our students with the skills and knowledge required to build a rewarding career in the profession of yacht and small-craft naval architecture.
- To support continued growth of the recreational and small-craft marine community through the development of well-trained, safety-oriented, boat designers developing better products for the benefit of the boating public.
- To provide continuing education to marine-industry professionals.